



The **FASTEST** Solutions for Piping Design and Analysis.

**Readme Supplement**  
**CAEPIPE**  
**Version 6.51**

**Disclaimer**

Please read the following carefully:

This software and this document have been developed and checked for correctness and accuracy by SST Systems, Inc. (SST) and InfoPlant Technologies Pvt. Ltd. (InfoPlant). However, no warranty, expressed or implied, is made by SST and InfoPlant as to the accuracy and correctness of this document or the functioning of the software and the accuracy, correctness and utilization of its calculations.

Users must carry out all necessary tests to assure the proper functioning of the software and the applicability of its results. All information presented by the software is for review, interpretation, approval and application by a Registered Professional Engineer.

CAEPIPE is a trademark of SST and InfoPlant.

CAEPIPE Version 6.51, ©2011, SST Systems, Inc. and InfoPlant Technologies Pvt. Ltd. All Rights Reserved.

---

SST Systems, Inc.  
1798 Technology Drive, Suite 236  
San Jose, California 95110  
USA

Tel: (408) 452-8111  
Fax: (408) 452-8388  
Email: [info@sstusa.com](mailto:info@sstusa.com)  
[www.sstusa.com](http://www.sstusa.com)

InfoPlant Technologies Pvt. Ltd.  
7, Crescent Road  
Bangalore – 560001  
India

Tel: +91-80-40336999  
Fax: +91-80-41494967  
Email: [iplant@vsnl.com](mailto:iplant@vsnl.com)  
[www.infoplantindia.com](http://www.infoplantindia.com)

**Annexure A**  
**ASME B31.1 Code Compliance**

## ASME B31.1 (2010)

### Allowable Pressure

For straight pipes and bends with seamless construction or designed for sustained operation below the creep range as per Eq. (7) and (9) of para.104.1.2, the allowable pressure is computed as follows.

$$P_a = \frac{2SEt_a}{D_o - 2Yt_a}$$

For straight pipes and bends with longitudinal weld or spiral weld construction designed for sustained operation within the creep range as per Eq. (11) of para.104.1.4, the allowable pressure is computed as follows.

$$P_a = \frac{2SEWt_a}{D_o - 2Yt_a}$$

where

$P_a$  = allowable pressure

SE = allowable stress as given in Appendix A of B31.1 (2010) Code, where

E = weld joint efficiency factor or casting quality factor

$t_a$  = available thickness for pressure design

=  $t_n \times (1 - \text{mill tolerance}/100) - \text{corrosion allowance}$

(Any additional thickness required for threading, grooving, erosion, corrosion, etc., should be included in corrosion allowance in CAEPIPE)

$t_n$  = nominal pipe thickness

$D_o$  = outside diameter of pipe

d = inside diameter of pipe

From Table 104.1.2 (A), the Pressure coefficient Y is implemented as follows.

Y = 0.0, for case iron and non ferrous materials.

$Y = \frac{d}{d + D_o}$ , if  $D_o/t_a < 6$ , for ferritic and austenitic steels designed for temperatures of 900°F (480°C)

and below

W = weld strength reduction factor as per Table 102.4.7. Refer to Annexure B for details on Weld strength reduction factor implemented in CAEPIPE.

For closely spaced miter bends, the allowable pressure is calculated from Eq. (C.3.1) of para.104.3.3.

$$P_a = \frac{SEt_a(R - r)}{r(R - r/2)}$$

where

r = mean radius of pipe =  $(D_o - t_n)/2$

R = equivalent bend radius of the miter

For widely spaced miter bends, the allowable pressure is calculated from Eq. (C.3.2) of para. 104.3.3.

$$P_a = \frac{SEt_a^2}{r(t_a + 1.25 \tan \theta \sqrt{rt_a})}$$

where

$\theta$  = miter half angle

## Sustained Stress

The stress ( $S_L$ ) due to sustained loads (pressure, weight and other sustained mechanical loads) is calculated from Eq. 15 of para.104.8.1

$$S_L = \frac{PD_o}{4t_n} + \frac{0.75iM_A}{Z} \leq S_h$$

where

P = maximum of CAEPIPE pressures P1, P2 and P3

$D_o$  = outside diameter

$t_n$  = nominal wall thickness

i = stress intensification factor. The product 0.75i shall not be less than 1.0.

$M_A$  = resultant bending moment due to weight and other sustained loads

Z = uncorroded section modulus; for reduced outlets, effective section modulus as per para 104.8.4

$S_h$  = hot allowable stress

## Occasional Stress

The stress ( $S_{Lo}$ ) due to occasional loads is calculated from Eq. 16 of para.104.8.2 as the sum of stress due to sustained loads ( $S_L$ ) and stress due to occasional loads ( $S_o$ ) such as earthquake or wind. Wind and earthquake are not considered concurrently.

$$S_{Lo} = \frac{P_{peak}D_o}{4t_n} + \frac{0.75iM_A}{Z} + \frac{0.75iM_B}{Z} \leq 1.2S_h$$

where

$M_B$  = resultant bending moment on the cross-section due to occasional loads such as thrusts from relief / safety valve loads, from pressure and flow transients, earthquake, wind etc.

$P_{peak}$  = peak pressure = (peak pressure factor in CAEPIPE) x P

## Expansion Stress Range (i.e., Stress due to Displacement Load Range)

The stress ( $S_E$ ) due to thermal expansion is calculated from Eq. 17 of para.104.8.3.

$$S_E = \frac{iM_C}{Z} \leq S_A$$

where

$M_C$  = resultant moment due to thermal expansion

$S_A = f(1.25S_C + 0.25S_h)$ , from Eq. (1A) of para. 102.3.2 (B)

$f$  = cyclic stress range reduction factor from Eq.(1C) of para. 102.3.2(B),

$f = 6/N^{0.2} \leq 1.0$  and  $f \geq 0.15$  with N being the total number of equivalent reference displacement stress range cycles expected during the service life of the piping

$S_C$  = allowable stress at cold temperature

When  $S_h$  is greater than  $S_L$ , the allowable stress range may be calculated as

$S_A = f[1.25(S_C + S_h) - S_L]$ , from Eq. (1B) of para. 102.3.2 (B)

This is specified as an analysis option: "Use liberal allowable stresses", in the menu Options->Analysis on the Code tab of CAEPIPE.

### Note:

Refer Annexure C for the details of "Thickness" and the "Section Modulus" used for weight, pressure and stress calculations.

## MANDATORY APPENDIX D

**Table D-1 Flexibility and Stress Intensification Factors**

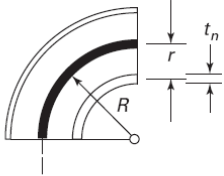
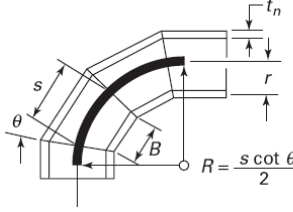
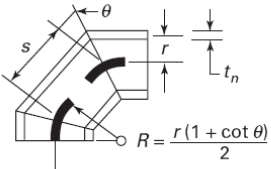
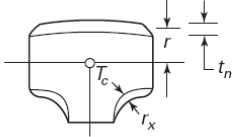
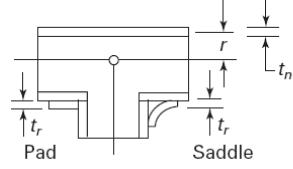
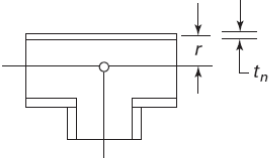
Description	Flexibility Characteristic, <i>h</i>	Flexibility Factor, <i>k</i>	Stress Intensification Factor, <i>i</i>	Sketch
Welding elbow or pipe bend [Notes (1), (2), (3), (4), (5)]	$\frac{t_n R}{r^2}$	$\frac{1.65}{h}$	$\frac{0.9}{h^{2/3}}$	
Closely spaced miter bend [Notes (1), (2), (3), (5)] $s < r(1 + \tan \theta)$ $B \geq 6 t_n$ $\theta \leq 22\frac{1}{2}$ deg	$\frac{s t_n \cot \theta}{2r^2}$	$\frac{1.52}{h^{5/6}}$	$\frac{0.9}{h^{2/3}}$	
Widely spaced miter bend [Notes (1), (2), (5), (6)] $s \geq r(1 + \tan \theta)$ $\theta \leq 22\frac{1}{2}$ deg	$\frac{t_n (1 + \cot \theta)}{2r}$	$\frac{1.52}{h^{5/6}}$	$\frac{0.9}{h^{2/3}}$	
Welding tee per ASME B16.9 [Notes (1), (2), (7)]	$\frac{3.1 t_n}{r}$	1	$\frac{0.9}{h^{2/3}}$	
Reinforced fabricated tee [Notes (1), (2), (8), (9)]	$\frac{\left(\frac{t_n + t_r}{2}\right)^{5/2}}{r (t_n)^{3/2}}$	1	$\frac{0.9}{h^{2/3}}$	
Unreinforced fabricated tee [Notes (1), (2), (9)]	$\frac{t_n}{r}$	1	$\frac{0.9}{h^{2/3}}$	

**Table D-1 Flexibility and Stress Intensification Factors (Cont'd)**

Description	Flexibility Characteristic, $h$	Flexibility Factor, $k$	Stress Intensification Factor, $i$	Sketch
Branch welded-on fitting (integrally reinforced) per MSS SP-97 [Notes (1), (2)]	$\frac{3.3t_n}{r}$	1	$\frac{0.9}{h^{2/3}}$	
Extruded outlet meeting the requirements of para. 104.3.1(G) [Notes (1), (2)]	$\frac{t_n}{r}$	1	$\frac{0.9}{h^{2/3}}$	
Welded-in contour insert [Notes (1), (2), (7)]	$3.1 \frac{t_n}{r}$	1	$\frac{0.9}{h^{2/3}}$	
Description	Flexibility Factor, $k$	Stress Intensification Factor, $i$		Sketch
Branch connection [Notes (1), (10)]	1	For checking branch end $1.5 \left(\frac{R_m}{t_{nh}}\right)^{2/3} \left(\frac{r'_m}{R_m}\right)^{1/2} \left(\frac{t_{nb}}{t_{nh}}\right) \left(\frac{r'_m}{r_p}\right)$		See Fig. D-1
Butt weld [Note (1)]				
$t \geq 0.237$ in., $\delta_{max} \leq 1/16$ in., and $\delta_{avg}/t \leq 0.13$	1	1.0 [Note (11)]		
Butt weld [Note (1)]				
$t \geq 0.237$ in., $\delta_{max} \leq 1/8$ in., and $\delta_{avg}/t =$ any value	1	1.9 max. or $[0.9 + 2.7(\delta_{avg}/t)]$ , but not less than 1.0 [Note (11)]		
Butt weld [Note (1)]				
$t < 0.237$ in., $\delta_{max} \leq 1/16$ in., and $\delta_{avg}/t \leq 0.33$	1			
Fillet welds	1	1.3 [Note (12)]		See Figs. 127.4.4(A), 127.4.4(B), and 127.4.4(C)
Tapered transition per para. 127.4.2(B) and ASME B16.25 [Note (1)]	1	1.9 max. or $1.3 + 0.0036 \frac{D_o}{t_n} + 3.6 \frac{\delta}{t_n}$		

Table D-1 Flexibility and Stress Intensification Factors (Cont'd)

Description	Flexibility Factor, $k$	Stress Intensification Factor, $i$	Sketch
Concentric reducer per ASME B16.9 [Note (13)]	1	2.0 max. or $0.5 + 0.01\alpha \left(\frac{D_2}{t_2}\right)^{1/2}$	
Threaded pipe joint or threaded flange	1	2.3	...
Corrugated straight pipe, or corrugated or creased bend [Note (14)]	5	2.5	...

## NOTES:

- (1) The following nomenclature applies to Table D-1:

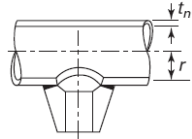
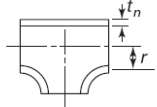
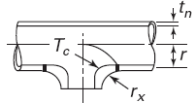
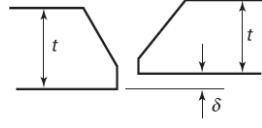
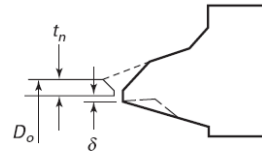
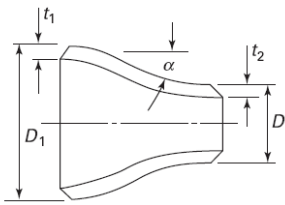
$B$  = length of miter segment at crotch, in. (mm)  
 $D_o$  = outside diameter, in. (mm)  
 $D_{ob}$  = outside diameter of branch, in. (mm)  
 $R$  = bend radius of elbow or pipe bend, in. (mm)  
 $r$  = mean radius of pipe, in. (mm) (matching pipe for tees)  
 $r_x$  = external crotch radius of welded-in contour inserts and welding tees, in. (mm)  
 $s$  = miter spacing at centerline, in. (mm)  
 $T_c$  = crotch thickness of welded-in contour inserts and welding tees, in. (mm)  
 $t_n$  = nominal wall thickness of pipe, in. (mm) (matching pipe for tees)  
 $t_r$  = reinforcement pad or saddle thickness, in. (mm)  
 $\alpha$  = reducer cone angle, deg  
 $\delta$  = mismatch, in. (mm)  
 $\theta$  = one-half angle between adjacent miter axes, deg

- (2) The flexibility factors  $k$  and stress intensification factors  $i$  in Table D-1 apply to bending in any plane for fittings and shall in no case be taken less than unity. Both factors apply over the effective arc length (shown by heavy centerlines in the sketches) for curved and miter elbows, and to the intersection point for tees. The values of  $k$  and  $i$  can be read directly from Chart D-1 by entering with the characteristic  $h$  computed from the formulas given.
- (3) Where flanges are attached to one or both ends, the values of  $k$  and  $i$  in Table D-1 shall be multiplied by the factor  $c$  given below, which can be read directly from Chart D-2, entering with the computed  $h$ : one end flanged,  $c = h^{1/6}$ ; both ends flanged,  $c = h^{1/3}$ .
- (4) The designer is cautioned that cast butt welding elbows may have considerably heavier walls than those of the pipe with which they are used. Large errors may be introduced unless the effect of these greater thicknesses is considered.
- (5) In large diameter thin-wall elbows and bends, pressure can significantly affect magnitudes of  $k$  and  $i$ . Values from the Table may be corrected by dividing  $k$  by

$$\left[ 1 + 6 \left( \frac{P}{E_c} \right) \left( \frac{r}{t_n} \right)^{7/3} \left( \frac{R}{r} \right)^{1/3} \right]$$

and dividing  $i$  by

$$\left[ 1 + 3.25 \left( \frac{P}{E_c} \right) \left( \frac{r}{t_n} \right)^{5/2} \left( \frac{R}{r} \right)^{2/3} \right]$$

- (6) Also includes single miter joints.
- (7) If  $r_x \geq D_{ob}/8$  and  $T_c \geq 1.5t_n$ , a flexibility characteristic,  $h$ , of  $4.4t_n/r$  may be used.
- (8) When  $t_r > 1.5t_n$ ,  $h = 4.05t_n/r$ .
- (9) The stress intensification factors in the Table were obtained from tests on full size outlet connections. For less than full size outlets, the full size values should be used until more applicable values are developed.

**Table D-1 Flexibility and Stress Intensification Factors (Cont'd)**

NOTES (Cont'd):

- (10) The equation applies only if the following conditions are met:
- (a) The reinforcement area requirements of para. 104.3 are met.
  - (b) The axis of the branch pipe is normal to the surface of run pipe wall.
  - (c) For branch connections in a pipe, the arc distance measured between the centers of adjacent branches along the surface of the run pipe is not less than three times the sum of their inside radii in the longitudinal direction or is not less than two times the sum of their radii along the circumference of the run pipe.
  - (d) The inside corner radius  $r_1$  (see Fig. D-1) is between 10% and 50% of  $t_{nh}$ .
  - (e) The outer radius  $r_2$  (see Fig. D-1) is not less than the larger of  $T_b/2$ ,  $(T_b + y)/2$  [shown in Fig. D-1 sketch (c)], or  $t_{nh}/2$ .
  - (f) The outer radius  $r_3$  (see Fig. D-1) is not less than the larger of:
    - (1)  $0.002\theta d_o$ ;
    - (2)  $2(\sin \theta)^3$  times the offset for the configurations shown in Fig. D-1 sketches (a) and (b).
  - (g)  $R_m/t_{nh} \leq 50$  and  $r'_m/R_m \leq 0.5$ .
- (11) The stress intensification factors apply to girth butt welds between two items for which the wall thicknesses are between  $0.875t$  and  $1.10t$  for an axial distance of  $\sqrt{D_o t}$ .  $D_o$  and  $t$  are nominal outside diameter and nominal wall thickness, respectively.  $\delta_{avg}$  is the average mismatch or offset.
- (12) For welds to socket welded fittings, the stress intensification factor is based on the assumption that the pipe and fitting are matched in accordance with ASME B16.11 and a full weld is made between the pipe and fitting as shown in Fig. 127.4.4(C). For welds to socket welding flanges, the stress intensification factor is based on the weld geometry shown in Fig. 127.4.4(B) and has been shown to envelop the results of the pipe to socket welded fitting tests. Blending the toe of the fillet weld, with no undercut, smoothly into the pipe wall, as shown in the concave fillet welds in Fig. 127.4.4(A) sketches (b) and (d), has been shown to improve the fatigue performance of the weld.
- (13) The equation applies only if the following conditions are met:
- (a) Cone angle  $\alpha$  does not exceed 60 deg, and the reducer is concentric.
  - (b) The larger of  $D_1/t_1$  and  $D_2/t_2$  does not exceed 100.
  - (c) The wall thickness is not less than  $t_1$  throughout the body of the reducer, except in and immediately adjacent to the cylindrical portion on the small end, where the thickness shall not be less than  $t_2$ .
- (14) Factors shown apply to bending; flexibility factor for torsion equals 0.9.



Chart D-1 Flexibility Factor,  $k$ , and Stress Intensification Factor,  $i$

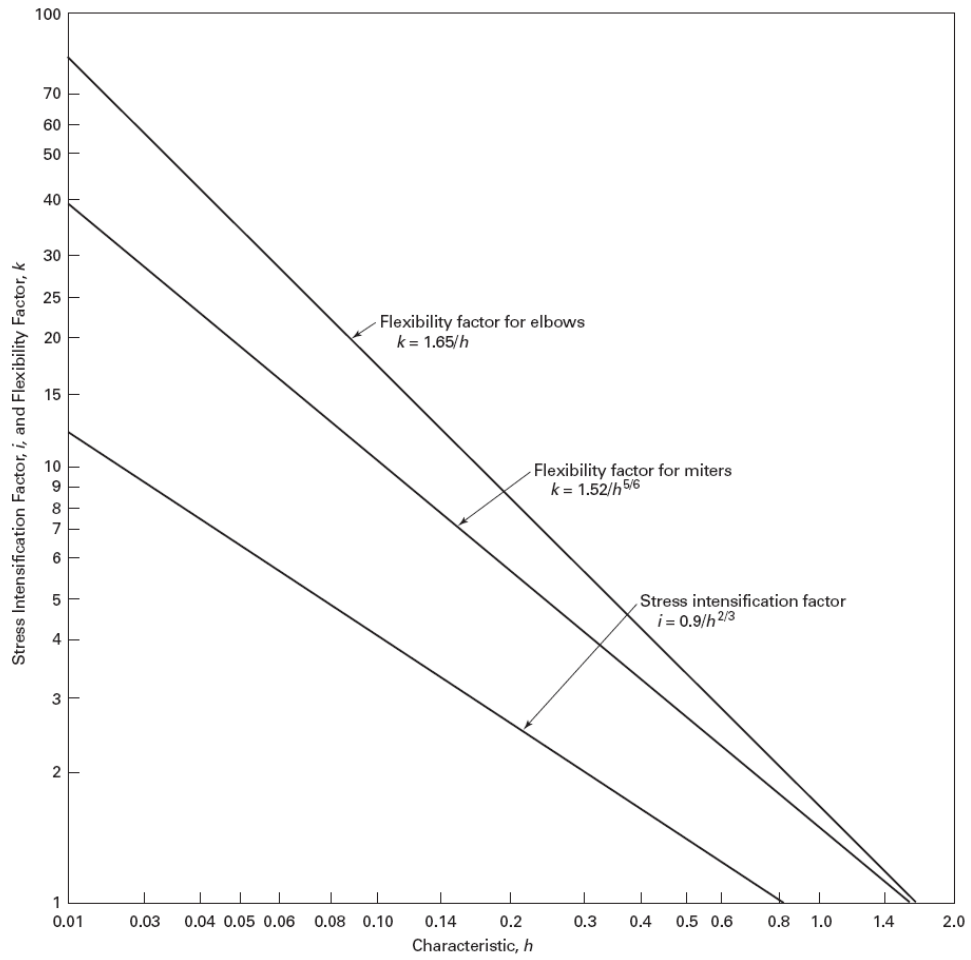
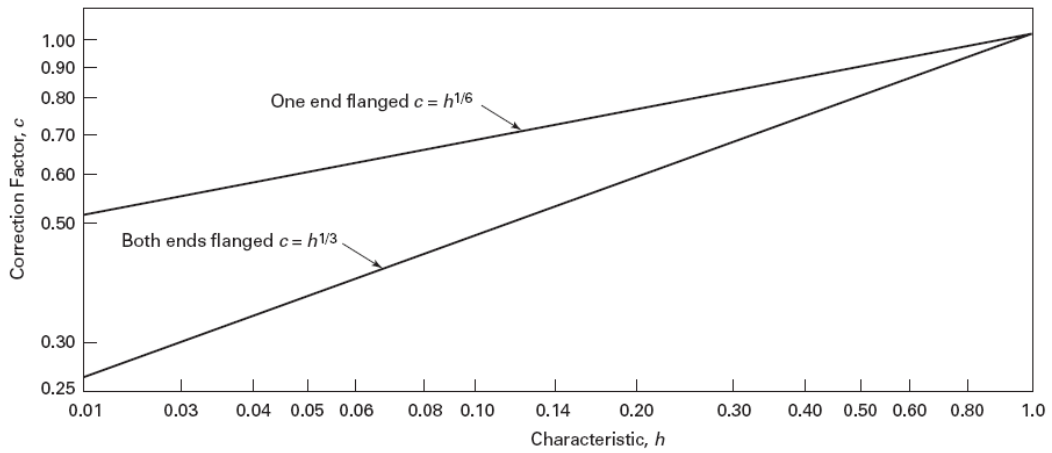

Chart D-2 Correction Factor,  $c$



## **Annexure B**

### **Weld Strength Reduction Factors built into CAEPIPE**

(as given in Table 102.4.7 of ASME B31.1 – 2010)

**Weld Strength Reduction Factors applied for calculating the Allowable Design Pressure of components (extracted from Table 102.4.7 of ASME B31.1-2010).**

Sl. No.	Steel Group	Weld Strength Reduction Factor for Temperature, Deg F (Deg C)										
		700	750	800	850	900	950	1000	1050	1100	1150	1200
		(371)	(399)	(427)	(454)	(482)	(510)	(538)	(566)	(593)	(621)	(649)
1	Carbon Steel (CS) with Max. Temp in CAEPIPE is <= 800 [see note 1 below]	1.00	0.95	0.91	NP	NP	NP	NP	NP	NP	NP	NP
2	CrMo Steels (Material Type = CS in CAEPIPE) with Max. Temp in CAEPIPE > 800	-	-	1.00	0.95	0.91	0.86	0.82	0.77	0.73	0.68	0.64
3	Ferritic Steels (FS)	1.00	1.00	1.00	1.00	1.00	1.00	0.95	0.91	0.86	0.82	0.77
4	Austenitic Steel (AS) [contd. in note 2 below]	1.00	1.00	1.00	1.00	1.00	1.00	0.95	0.91	0.86	0.82	0.77
5	Materials other than those stated from Sl. Nos. 1 to 4	1.00	1.00	1.00	1.00	1.00	1.00	1.00	1.00	1.00	1.00	1.00

Notes:

- NP = Not permitted
- For Austenitic Steels (including 800H and 800 HT) the values upto 1500 deg F are as follows:

Temperature, deg F	Temperature, deg C	Weld Strength Reduction Factor
1250	677	0.73
1300	704	0.68
1350	732	0.64
1400	760	0.59
1450	788	0.55
1500	816	0.50

## **Annexure C**

**Thickness and Section Modulus used in Weight, Pressure and  
Stress Calculations for ASME B31.x Codes**

Particulars	Allowable Pressure	Pipe Weight	Sustained Stress	Expansion Stress	Occasional Stress
<b>B31.1 (2010)</b>					
Pipe Thickness used	Nominal Thk. x (1-mill tolerance/100) – Corrosion allowance	Nominal Thickness	Nominal Thickness	-	Nominal Thickness
Section Modulus used	-	-	Uncorroded Section Modulus; For Branch, effective section modulus	Uncorroded Section Modulus; For Branch, effective section modulus	Uncorroded Section Modulus; For Branch, effective section modulus
<b>B31.3 (2008)</b>					
Pipe Thickness used	Nominal Thk. x (1-mill tolerance/100) – Corrosion allowance	Nominal Thickness	Nominal Thickness - Corrosion allowance	-	Nominal Thickness – Corrosion allowance
Section Modulus used	-	-	<i>Corroded</i> Section Modulus; For Branch, effective section modulus	Uncorroded Section Modulus; For Branch, effective section modulus	<i>Corroded</i> Section Modulus; For Branch, effective section modulus
<b>B31.4 (2009)</b>					
Pipe Thickness used	Nominal Thk. x (1-mill tolerance/100) – Corrosion allowance	Nominal Thickness	Nominal Thickness	-	Nominal Thickness
Section Modulus used	-	-	Uncorroded Section Modulus; For Branch, effective section modulus	Uncorroded Section Modulus; For Branch, effective section modulus	Uncorroded Section Modulus; For Branch effective section modulus
<b>B31.5 (2006)</b>					
Pipe Thickness used	Nominal Thk. x (1-mill tolerance/100) – Corrosion allowance	Nominal Thickness	Nominal Thickness – Corrosion allowance	-	Nominal Thickness – Corrosion allowance
Section Modulus used	-	-	<i>Corroded</i> Section Modulus; For Branch, effective section modulus	Uncorroded Section Modulus; For Branch, effective section modulus	<i>Corroded</i> Section Modulus; For Branch, effective section modulus

Particulars	Allowable Pressure	Pipe Weight	Sustained Stress	Expansion Stress	Occasional Stress
<b>B31.8 (2007)</b>					
Pipe Thickness used	Nominal Thk. x (1-mill tolerance/100) – Corrosion allowance	Nominal Thickness	Nominal Thickness	-	Nominal Thickness
Section Modulus used	-	-	Uncorroded Section Modulus; For Branch, effective section modulus	Uncorroded Section Modulus; For Branch, effective section modulus	Uncorroded Section Modulus; For Branch, effective section modulus
<b>B31.9 (2004)</b>					
Pipe Thickness used	Nominal Thk. x (1-mill tolerance/100) – Corrosion allowance	Nominal Thickness	Nominal Thickness	-	Nominal Thickness
Section Modulus used	-	-	Uncorroded Section Modulus; For Branch, effective section modulus	Uncorroded Section Modulus; For Branch, effective section modulus	Uncorroded Section Modulus; For Branch, effective section modulus

**Note:**

1. Corrosion allowance includes thickness required for threading, grooving, erosion, corrosion etc.
2. Uncorroded section modulus = section modulus calculated using the nominal thickness.
3. Corroded section modulus = section modulus calculated using the “corroded thickness”  
corroded thickness = nominal thickness – corrosion allowance
4. Effective section modulus = section modulus calculated using effective branch thickness, which is lesser of  $i_i t_b$  or  $t_h$   
where,  $t_b$  = branch nominal thickness,  $t_h$  = header nominal thickness,  $i_i$  = in-plane SIF at branch